



# Science of Gaming

Learn about the effects of gaming on your brain and learning capacity! Discuss whether or not games like Portal, Bioshock or Fallout are plausible in reality!

February 23<sup>rd</sup>, 2015 3:30 PM - 4:30 PM  
Mitchell Hall 121

Attend S<sup>3</sup> event for a chance to win a **FREE**  
Kaplan course, Explora! Membership  
or \$40 to Rude Boy Cookies

Like Our Page At: [Facebook.com/S3UNM](https://www.facebook.com/S3UNM)

**Support, Strength, Success**





# Support, Strength, Success

S<sup>3</sup> is dedicated to creating a community of support, friendship, and resources for your journey as a Science, Technology, Engineering, and Math (STEM) student at UNM and CNM.



S3atunm@gmail.com

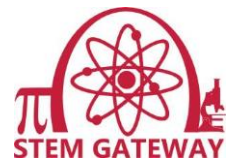

<http://goo.gl/pNs0qB>

PORTAL



# What Is Happening?

- ▶ **Main Character:** Chell
- ▶ **Robot narrator:** GLaDOs (Genetic Lifeform and Disk Operating system)
- ▶ **Weapon:** the Aperture Science Handheld Portal Device

# The Aperture Science Handheld Portal Device

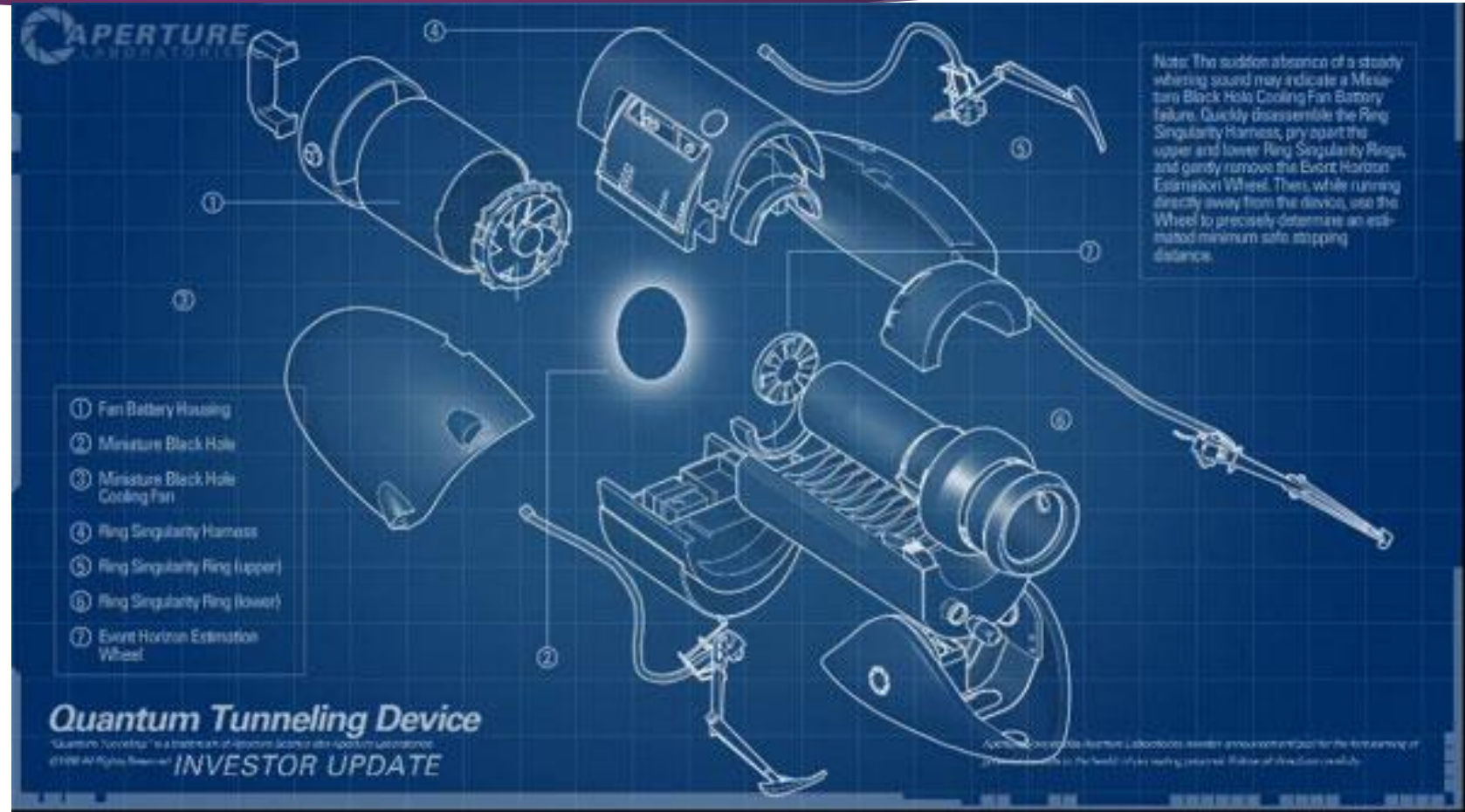



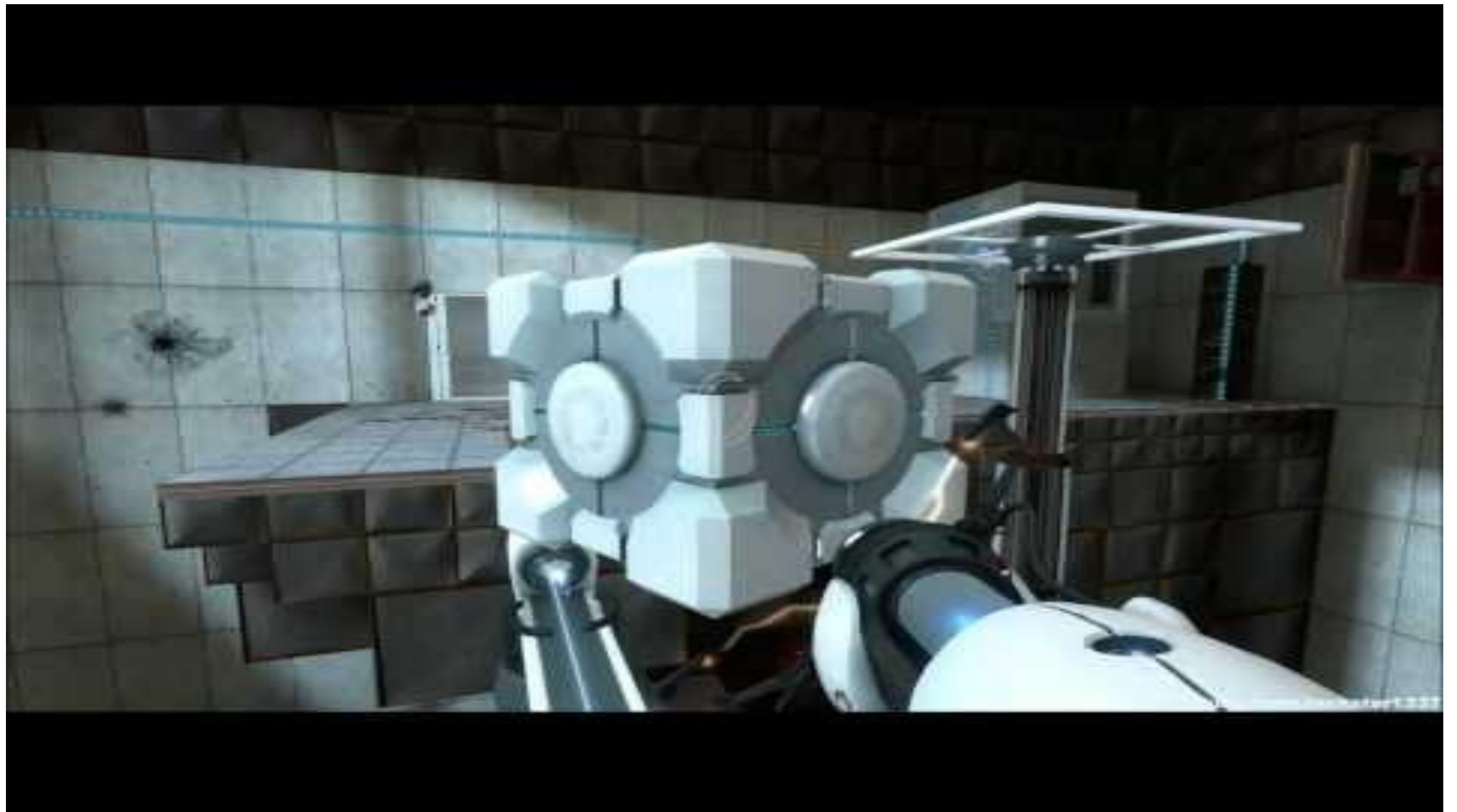

# Nature of Portals

- ▶ A doorway that connects two distant locations separated by spacetime
- ▶ Instantaneous transport of an object
- ▶ Could be used for teleportation, time portal, other planes of existence



# Fun with Portals: Perpetual Motion



# Inconsistencies

- ▶ There must be a power source with a finite level of power
  - ▶ Cannot create energy, no free energy
  - ▶ Possible solution: energy is generated as objects are moving through the portals
- ▶ What happens if the portal closes when there's something in it?
  - ▶ Object should be bisected or object blocks the portal from closing but are instead ejected from portal



NOW YOU'RE THINKING WITH PORTALS.





BIOSHOCK





# Bioshock Trailer

<http://youtu.be/zHRNLix6qwY>

WELCOME TO RAPTURE

BIOSHOCK







*“Evolution in a bottle!”*



**PLASMIDS BY RYAN INDUSTRIES**



**PLASMIDS BY RYAN INDUSTRIES**

MAKE GIFS AT [GIFSOUP.COM](http://GIFSOUP.COM)





PLASMIDS BY RYAN INDUSTRIES

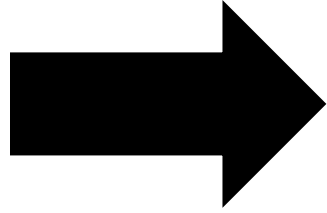









# What are Plasmids?

- ▶ Small, circular DNA found in bacteria
  - ▶ Different bacterial plasmids do different things
- ▶ Plasmids traits can be passed to different organisms via horizontal gene transfer
- ▶ Can be manipulated for use in genetic research

# Inconsistencies

- ▶ Sea slugs are not bacteria
- ▶ Why inject them into orphaned girls?
- ▶ Superpowers?

Questions/Discussion Time!